

# Powers™ Controls

## VP 658 S and VP 658 SC Powertop Sequence and Sequence Changeover Valves

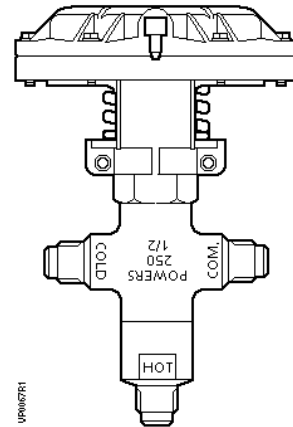

### Description

The VP 658 S sequence and VP 658 SC sequence changeover valves are designed to select and modulate the flow of either hot or chilled water without mixing for radiant panel and similar four-pipe single coil/panel applications. The sequence valve has two inlets and one outlet whereas the changeover valve has one inlet and two outlets.

### Features

- Stainless steel stem for smooth operation and durability
- Large diaphragm area for control accuracy and tight close off
- Removable actuator for ease of servicing
- Durable actuator made to eliminate electrolytic action
- Replaceable disc assemblies
- Matched sequencing of control and changeover valves

### Product Numbers

**Table 1.**

| Product Number | CV  | Valve Type | Valve Size |
|----------------|-----|------------|------------|
| 658-0050       | 1.5 | Sequence   | 1/2"       |
| 658-0051       | 2.5 | Sequence   | 1/2"       |
| 658-0052       | 2.5 | Changeover | 1/2"       |

### Warning/Caution Notations

|                |  |   |
|----------------|--|---|
| <b>WARNING</b> |  | Personal injury/loss of life may occur if you not perform a procedure as specified.         |
| <b>CAUTION</b> |  | Equipment damage, or loss of data may occur if you do not perform a procedure as specified. |

|                       |  |   |                    |
|-----------------------|--|---|--------------------|
| <b>Specifications</b> | Valve size/ capacity   | See Tables 1 and 2.   |                    |
|                       | Body Style   | 1/2" SAE Flared   |                    |
|                       | <b>Valve Body</b>  | Body type   | 2 inlets, 1 outlet |
|                       |  | Sequence<br>Changeover  | 1 inlet, 2 outlets |
|                       | Action   | Normally Open (NO) Hot to common<br>Normally Closed (NC) Cold to common |                    |
| Valve stroke          | 13/32-inch (10 mm)   |   |                    |
| <b>Material</b>       | Body   | Bronze  |                    |
|                       | Seat   | Bronze  |                    |
|                       | Stem   | Stainless steel   |                    |
|                       | Stem packing (O-rings)                                       | EP rubber   |                    |
|                       | Shut-off disc  | Buna-N  |                    |
|                       | Throttle plug  | Brass   |                    |
| <b>Valve Actuator</b> | Nominal spring range   | See Figure 1.   |                    |
|                       | Diaphragm  |   |                    |
|                       | Effective area   | 11 inch <sup>2</sup> (71 cm <sup>2</sup> )                              |                    |
|                       | Material   | EP rubber   |                    |
|                       | Max. air pressure  | 30 psig (210 kPa)   |                    |
| <b>Operating</b>      | Controlled medium  | Water, ethylene glycol solution   |                    |
|                       | Flow characterization:                                       |   |                    |
|                       | Sequence   | Equal percentage  |                    |
|                       | Changeover   | Quick opening   |                    |
|                       | Ambient temperature range                                    | 35°F to 140°F (2°C to 60°C)   |                    |
|                       | Body rating, max temperature/pressure                        | See Table 3.  |                    |
|                       | Max. pressure difference between hot and cold ports:         |   |                    |
|                       | Sequence   | 50 psig (350 kPa)   |                    |
|                       | Changeover   | 10 psig (69 kPa)  |                    |
|                       | Max. differential pressure for modulating service (sequence) | 25 psi (170 kPa)  |                    |
| Dimensions            | See Figure 8.  |   |                    |

**Application**

A typical application of sequence and changeover valves controls heating or cooling in a single coil or radiant panel. These four-pipe systems have hot water and chilled water available at the same time. Figure 2 shows a unit conditioner application.

The direct acting thermostat gradually positions the sequence valve and the changeover valve to maintain space temperature according to the control schedule shown in Figure 1. The sequence valve gradually controls the hot or chilled water flow into the coil. The changeover valve diverts the water leaving the coil to the correct return line.

**Table 2. Water Capacity - U.S. Gallons Per Minute.**

| Valve Size and Type | Pressure Differential psi |     |   |     |     |     |     |      |      |
|---------------------|---------------------------|-----|---|-----|-----|-----|-----|------|------|
|                     | CV 1                      | 2   | 4 | 6   | 8   | 10  | 15  | 20   | 25   |
| 1/2" Sequence       | 1.5                       | 2.1 | 3 | 3.7 | 4.2 | 4.7 | 5.8 | 6.7  | 7.5  |
| 1/2" Sequence       | 2.5                       | 3.5 | 5 | 6.1 | 7.1 | 7.9 | 9.7 | 11.2 | 12.5 |
| 1/2" Changeover     | 2.5                       | -   | - | -   | -   | -   | -   | -    | -    |

**Table 3. Body Rating.**

| Temperature<br>°F (°C) | Pressure<br>psig (kPa)<br>ANSI Class 250<br>Bronze Body |
|------------------------|---|
| -20 to 150 (-30 to 66) | 250 (1720)  |
| 200 (93)               | 250 (1720)  |
| 250 (121)              | 250 (1720)  |

Overall rating limited to 250 psig.

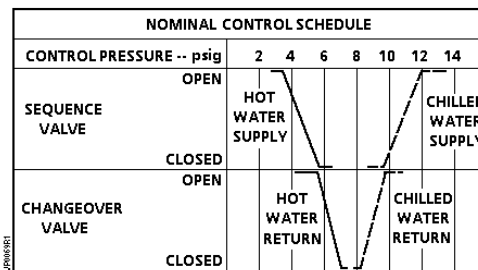

**Figure 1. Nominal Control Schedule.**

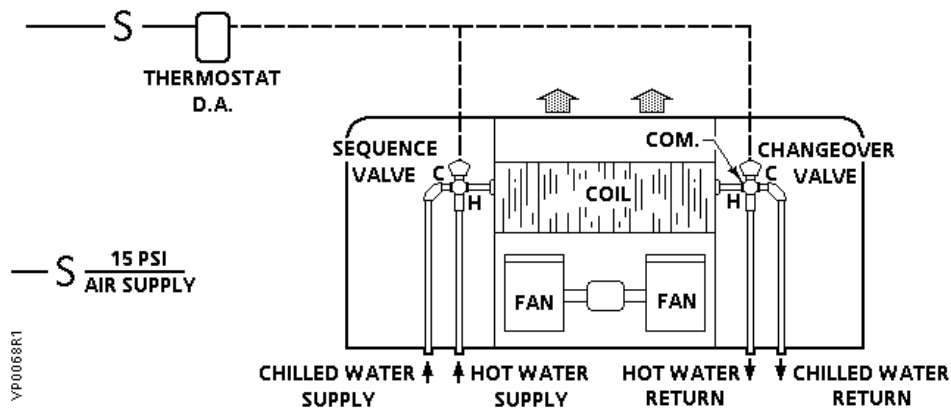

**Figure 2. Unit Conditioner Application.**

**Operation**

The sequence valve, (Figure 3), is piped to the inlet of a coil. Therefore, it has hot water supply and chilled water supply connected to it. The changeover valve, (Figure 4), is piped to the outlet of the coil. Therefore, it has the hot water and chilled water returns connected to it. For the sequence valve, water should flow into the hot and cold ports and out of the common. For the changeover valve, flow should be into the common and out of the hot and cold ports.

The operation of the sequence valve and changeover valve is similar. The main difference is the control pressure at which the upper port opens and the lower port closes on each valve.

With no air pressure to the Powertop the chilled water port (upper disc) is closed and the hot water port (lower disc) is open. As air pressure increases, the lower disc is gradually moved toward its seat, reducing the flow of hot water. After the lower disc closes against its seat, stopping the flow of hot water, there is a dwell period (dependent upon water differential pressures) during which there is no flow through the valve. As the control air pressure continues to increase, it overcomes the disc spring force to gradually move the upper disc away from the seat permitting the flow of cold water.

As the differential water pressure increases, the hot port (lower disc) will close at a higher Powertop pressure and cold port (upper disc) opens at a lower Powertop pressure. The effect is to narrow the dwell period.

Figure 1 shows the nominal control schedule for the sequence and changeover valves.

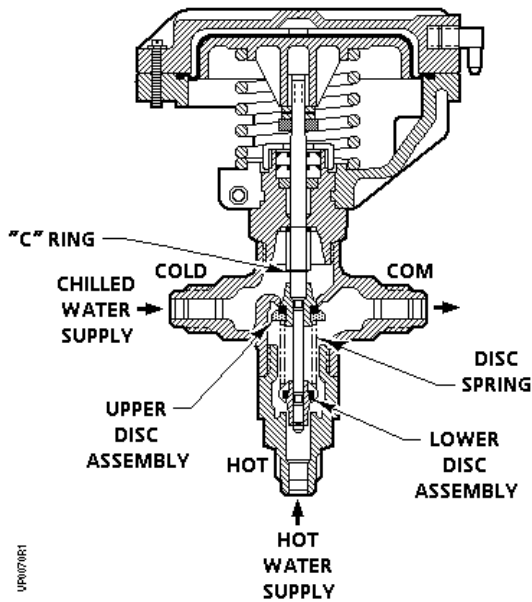

**Figure 3. Sequence Valve.**

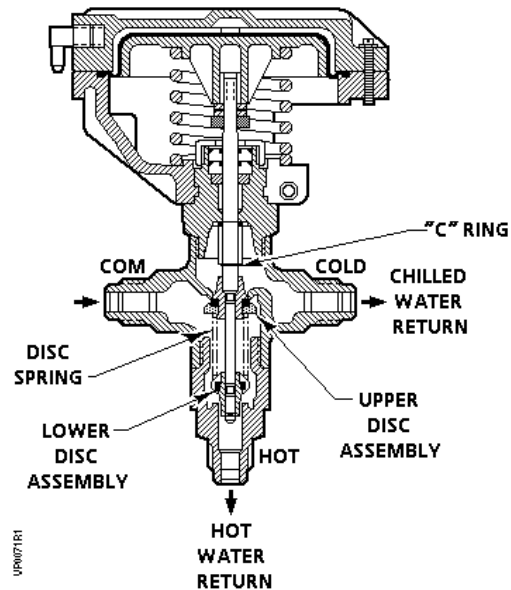

**Figure 4. Changeover Valve.**

---

## Sizing

The sizing of a valve is important for correct system operation. An undersized valve will not have sufficient capacity at maximum load. An oversized valve may initiate cycling and the seat and disc may be damaged because of the restricted opening. Correct sizing of the control valve for actual expected conditions is considered essential for good control.

Some variables that must be determined are:

1. The maximum inlet temperature and pressure of medium at the valve.
2. The pressure differential that will exist across the valve under maximum load demand.
3. The maximum capacity the valve must deliver.
4. The maximum medium pressure differential the valve actuator must close against.
5. See *AB-1 "Valve Selection and Sizing"* for further recommendations.

See Table 2 for valve capacity.

The Powertop sequence changeover valve does not require sizing in the same manner as the sequence valve. The changeover valve does not control the quantity of water flowing through the system but diverts the flow from one return to the other.

**NOTE:** Even though it is not necessary to "size" a changeover valve, the pressure drop across the valve will add resistance to the flow of the medium.

---

## Installation

- Leave plastic cover in place until after painting.
  - In concealed installations, sufficient room should be allowed so that the actuator assembly can be removed for valve servicing. A distance of three inches (76 mm) from top of housing is sufficient.
  - Install changeover valve so that flow is out of the ports marked "hot" and "cold". The inlet is the common port.
  - Install sequence valve so that flow is into the ports marked "hot" and "cold". The outlet is the common port.
  - The valve housing should never be used as a lever arm to tighten the body when taking up on a thread.
  - For best performance install the valve vertically in an upright position.
  - Installation of hand valves on supply and return piping is recommended to allow servicing.
-

**Table 4. Part Numbers (See Figure 5).**

| Item | Description  | Qty | Part Number   |                              |                              | Material           |
|------|--|-----|---|------------------------------|------------------------------|--------------------|
|      |  |     | C <sub>V</sub> = 1.5<br>seq.                          | C <sub>V</sub> = 2.5<br>seq. | C <sub>V</sub> = 2.5<br>c.o. |                    |
| 1    | Actuator Housing - Upper   | 1   | See <i>Item 26</i> Assembly.                          |                              |                              | Nylon              |
| 2    | Thread Forming Screw   | 8   | See <i>Item 27</i> Kit<br>or <i>Item 26</i> Assembly. |                              |                              | Steel              |
| 3    | Diaphragm  | 1   |   |                              |                              | EP Rubber          |
| 4    | Piston Plate Assembly  | 1   | See <i>Item 26</i> Assembly.                          |                              |                              | Aluminum & Steel   |
| 5    | Actuator Compression Spring  | 1   |   |                              |                              | Cadmium Pl. Steel  |
| 6    | Actuator Housing - Lower   | 1   |   |                              |                              | Nylon              |
| 7    | Stem Locknut   | 2   | 041-117J  | —————→                       |                              | Steel              |
| 8    | Cap  | 1   | -   | -                            | -                            | Brass              |
| 9    | Packing Washer   | 1   | See <i>Item 28</i> Kit.                               |                              |                              | Copper             |
| 10   | Large O-Ring   | 2   |   |                              |                              | EP Rubber          |
| 11   | Small O-Ring   | 2   |   |                              |                              | EP Rubber          |
| 12   | O-Ring Retainer  | 2   |   |                              |                              | Brass              |
| 13   | Packing Ring   | 1   |   |                              |                              | Teflon             |
| 14   | Bonnet   | 1   | -   | -                            | -                            | Brass              |
| 15   | Stem   | 1   | 658-356   | —————→                       |                              | Stainless Steel    |
| 16   | Spacer   | 1   | 656-321   | —————→                       |                              | Brass              |
| 17   | "C" Ring   | 3   | 047-064   | —————→                       |                              | Stainless Steel    |
| 18   | "O" Ring   | 2   | 047-004   | —————→                       |                              | Buna-N             |
| 19   | Upper Disc Assembly  | 1   | 656-265   | 656-365                      | Item 28                      | Brass & Sty. Buta. |
| 20   | Disc Spring  | 1   | 656-419   | 656-419                      | 656-418                      | Stainless Steel    |
| 21   | Lower Disc Assembly  | 1   | 656-266   | 656-330                      | Item 28                      | Brass & Sty. Buta. |
| 22   | Valve Body   | 1   | -   | -                            | -                            | Bronze             |
| 23   | Lower Body   | 1   | -   | -                            | -                            | Brass              |
| 24   | O-Ring   | 2   | See <i>Item 30</i> Ass'y.                             |                              | Items 29<br>and 30           | EP Rubber          |
| 25   | Back-Up Ring   | 2   | See <i>Item 28</i> Kit                                |                              |                              | Teflon®            |
| 26   | Actuator Assembly Includes Items 1, 2, 3, 4, 5, and 6                    | -   | 658-066   | —————→                       |                              | -                  |
| 27   | Diaphragm Kit Includes Items 2, 3 (Pkg. of 5 Diaphragms)                 | -   | 658-166   | —————→                       |                              | -                  |
| 28   | Stem Packing Kit Includes Items 9 through 13, 24, and 25 (For 10 valves) | -   | 658-167   | —————→                       |                              | -                  |
| 29   | Disc Assembly Kit Includes Items 19, 21, and 24                          | -   | N/A   | N/A                          | 657-813                      | -                  |
| 30   | Valve Body Assembly, Flared Includes Item 7 through 25                   | -   | 658-333   | 658-334                      | 658-341                      | -                  |

**Valve Components**

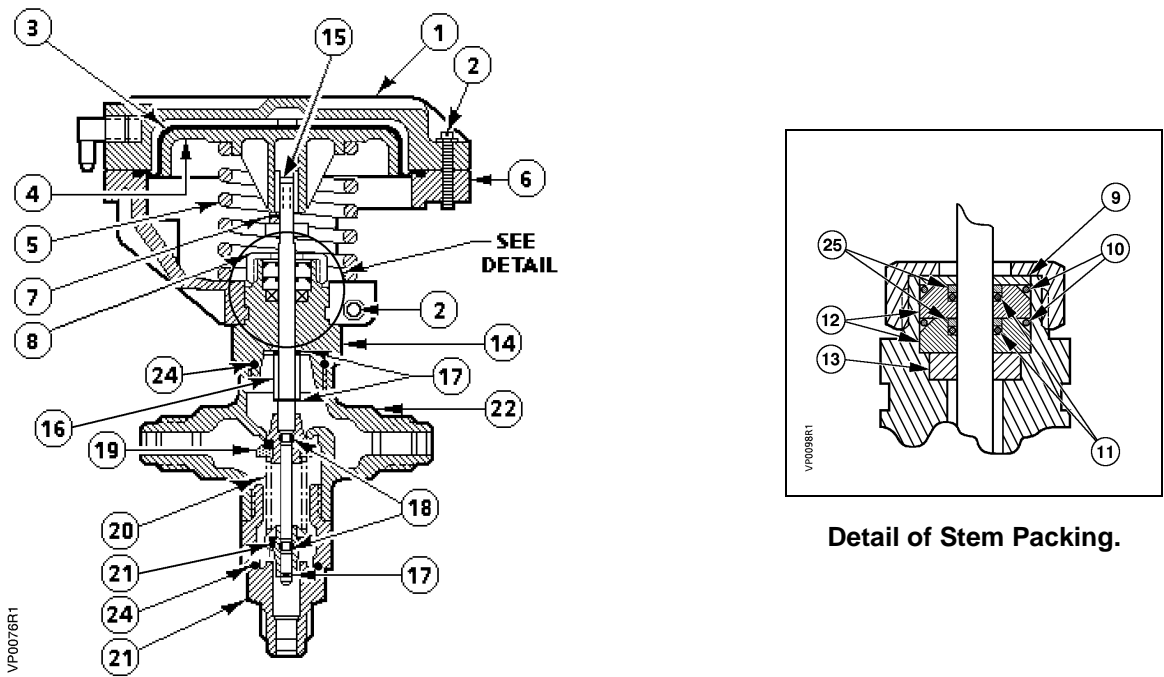

**Figure 5. Valve Construction (See Table 4).**

**Service**



**WARNING:**

Before doing any service work, shut off the medium (water, etc.) to the valve and remove and cap the airline to the valve actuator to prevent personal injury and equipment damage.

**Diaphragm Replacement**

Installation instructions are packaged with the replacement kit.

**Stem Packing Replacement**

See *TB 246* (155-301P25) VP 658 Powertop Valve Repacking Kit for recommended procedure.

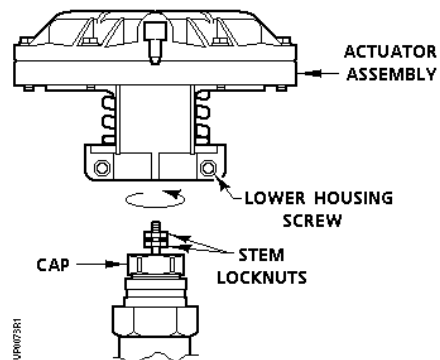

**Figure 6. Actuator Assembly Removal.**

### **Actuator Assembly Replacement**

1. Loosen the two lower housing screws that clamp it to the bonnet.
2. Using two open-end wrenches, loosen the stem locknuts.
3. Unscrew actuator assembly from stem and remove it, as shown in Figure 6.
4. Before installing new actuator assembly, push stem down. There must be at least 1/16-inch (2 mm) clearance between lower stem locknut and cap.
5. Pull stem up and install actuator assembly.
6. Screw stem into piston plate and tighten locknuts.
7. Tighten lower housing screws. Don't overtighten these screws.

The replacement is now complete.

---

### **Valve Disc Replacement Disassembly**

1. Remove actuator as described in the *Actuator Assembly Replacement* section.
2. Remove stem locknuts.
3. Remove lower body and pull stem assembly through bottom port.
4. Place stem assembly in a vise. Hold assembly by upper disc assembly, *NOT BY THE STEM*. The stem must be smooth to provide a good seal and move freely. Place 1/2-inch (13 mm) open-end wrench on lower disc assembly and compress disc spring so "C" ring can be pulled out with long nose pliers. Be careful; disc spring has a lot of force.
5. Disassemble as shown in Figure 7. Upper and lower disc assemblies can now be removed and replaced.
6. If small O-rings need to be replaced, use a small screwdriver to free them from groove.
7. Remove the cap from the bonnet. Then remove the washer, O-ring packing, and packing ring as shown in Figure 7.

### **Assembly**

1. Reassemble stem assembly. See step 4 in the *Disassembly* section and Figure 7. Be careful, it requires considerable force to compress disc spring so "C" ring can be replaced on valve stem. Slide stem assembly into bonnet.
2. Return lower body to bottom of valve body and tighten securely.
3. Replace packing ring, O-rings packing and washer using repacking kit 658-167. Follow recommended procedure outlined in TB246 included in 658-167 kit. Packing must be replaced because it is normally damaged during disassembly.
4. When packing has been replaced and valve body is reassembled, replace actuator assembly by reversing steps 1 through 3 in the *Actuator Assembly Replacement* section.

The replacement is now complete.

---



**Valve Disc  
Replacement,  
continued**

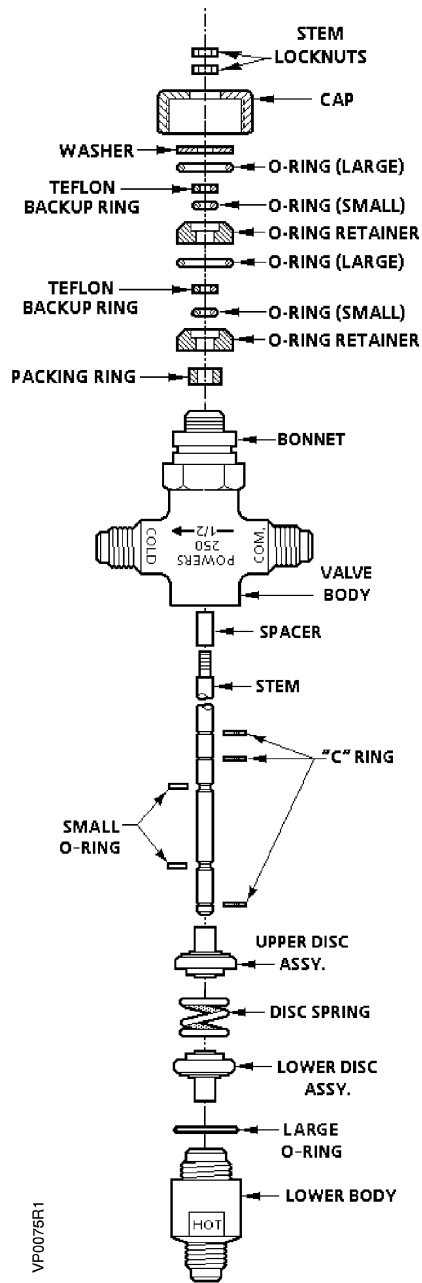

**Figure 7. Valve Body Assembly.**

## Dimensions

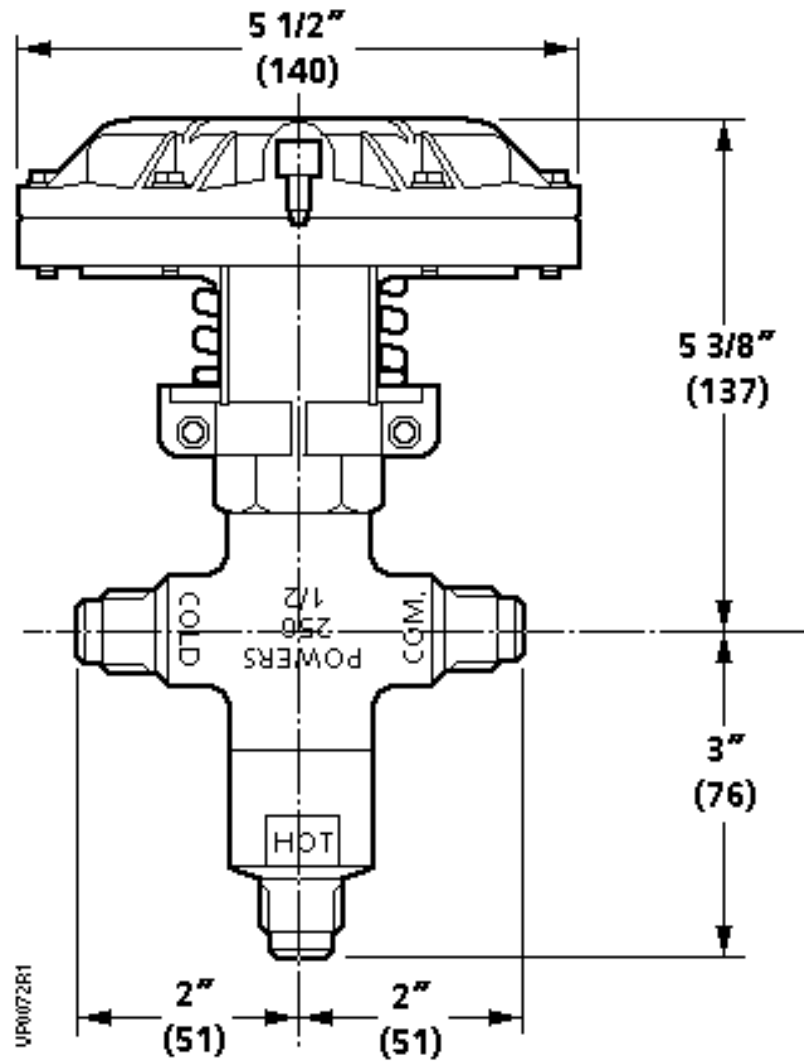

Figure 8. Dimensions.

Information in this publication is based on current specifications. The company reserves the right to make changes in specifications and models as design improvements are introduced. Powers is a registered trademark of Siemens Industry, Inc. Product or company names mentioned herein may be the trademarks of their respective owners. © 2008 Siemens Industry, Inc.